

User Manual Digital humidity controller



FOX-1SH(R) (Temp. & Humi. sensor) **FOX-1H** (Humi. sensor)

※ Thank you for purchase CONOTEC's product. This user manual is provided to prevent product damage by carelessness and to inform the users of exact way of operation. Please keep it well and refer to it when you have any question in using the product.

This Manual in English is available on our web site.

1 Model Composition

Model	Output	Sensor	Range	RS485
FOX-1H	1c 250Vac2A	HCPV-220H	10%~95%Rh	-
FOX-1SH	1a 250Vac2A	DS-SH series	0%~100%Rh	○
FOX-1SHR				○

2 Safety Precaution

Please read all precautionary information before use, to ensure proper usage.

※ The specification and external dimensions etc of the Product contained in this Manual can be changed without prior notice for further improvement in the product performance.

Warning

- This Product is not designed to be used as a safety device. Please add a secondary safety device if this Product is used as a controller for a device that has the potential of causing personal injury, damage to the surrounding machine or damage to other properties.
- Do not perform any wiring, maintenance or repair work while the Product is connected to power.
- Check the terminal number before connecting to power.
- Do not disassemble, process, improve or repair the Product.

Caution

- Please read and observe safety warnings and cautions as well as the method of operation before installation, and use the Product within the scope of specified and permitted usage.
- Do not wire or install the Product on a motor or a solenoid having a high level of inductive load.
- If the sensor of the Product needs to be extended, make sure to use the same cable as the original. The length of cable should be kept at a minimum.
- Do not use a part that may generate arc when it is open or closed near or on the same power supply.
- Keep the power cable away from a high voltage wire. Install the Product away from water, oil and excessive dust.
- Install the Product away from direct sunlight and rain.
- Install the Product away from strong magnetic force, noise, vibration and impact.
- Keep the Product away from a place exposed to strong alkaline or acid materials.
- Do not splash water directly onto the Product to clean in case the Product is installed in the kitchen.
- Do not install the Product in a place exposed to high temperature/humidity.
- Use the sensor cable with care not to allow cut or scratch.
- Keep the sensor cable away from a signal cable, power cable, power and load cable. Use a separate cable pipe.
- Please note that no after-sales service will be available if the Product is disassembled or altered without permission.
- Please observe the hazard and precautionary statements shown on the terminal wiring diagram.
- Do not use the Product near a device generating a significant level of high frequency (such as high frequency welding machine, high frequency sewing machine, high frequency radio, high capacity SCR controller etc).
- Use of the Product in violation of the manufacturer's instructions may cause personal injury or physical damage.
- Keep the Product away from the reach of children as this is not a toy.
- The Product must be installed by a qualified technician only.
- The Company will not be held responsible for any damage caused by non observance of the above instructions or the user's negligence.

Hazard

- Hazard related to electric shock
- 1. Electric shock – Do not touch the AC terminal while current is flowing. It may cause electric shock.
- 2. Disconnect the input power before checking the input power.

3 Front Operation & Display

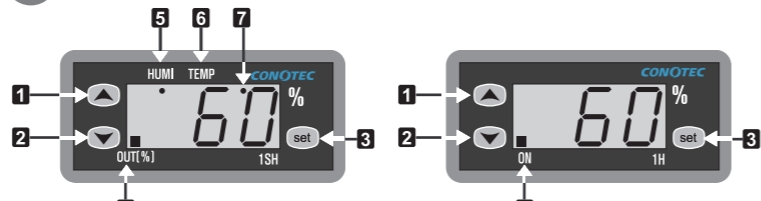

- 1 Up switch (UP)
- 2 Down switch (DN)
- 3 Set switch (SET)
- 4 Output display
- 5 Humidity display (FOX-1SH(R) model)
- 6 Temperature display (FOX-1SH(R) model)
- 7 Sensor communication status display

- * The communication status light blinks when sensor communication is not smooth
- * FOX-1SH(R) : Humidity display and control + Temperature display
The current status display has two modes and UP (increase)/DN (decrease) switches can change "humidity display/temperature display".

FOX-1H : Humidity display and control function

4 Terminal connection diagram

< FOX-1SH / FOX-1SHR >

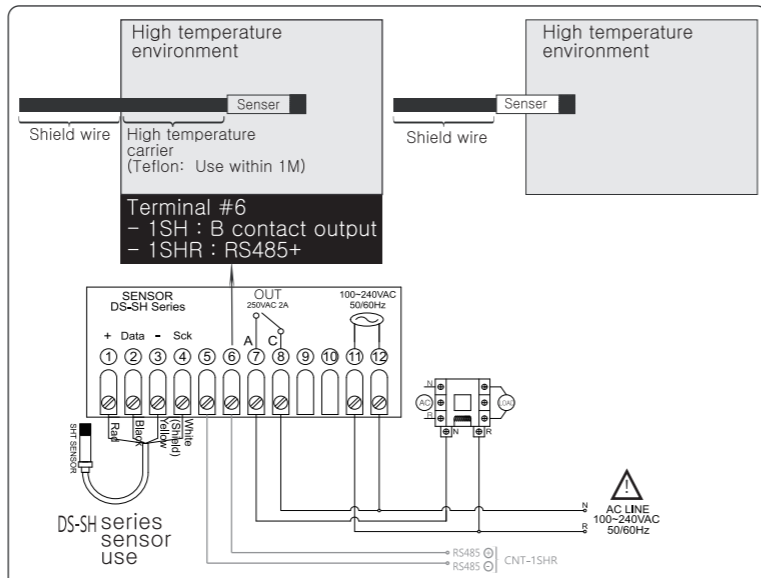

Ref1. Detailed specifications for the applicable sensor specifications, see the back of the '10. sensor's specifications'.

Caution1. Please make use of the shield wire when lengthening of the sensor wire, and in case of using in the high temperature range of 65°C~80°C, surely use the high temperature using wire(Teflon wiring).

Caution2. Please make the operating machine(load) be driven with using the power relay or magnet outside surely because its output specification of inside relay is less than 250VAC 2A

< FOX-1H >

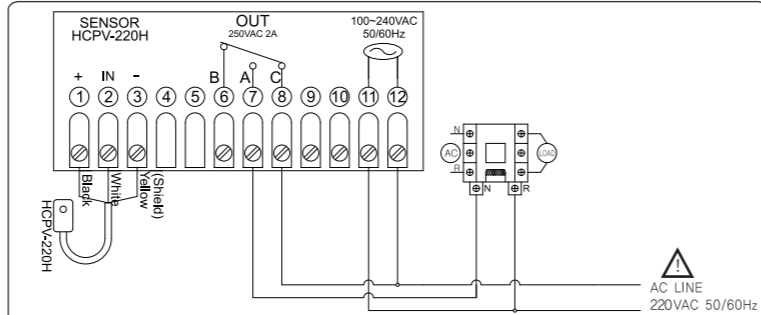

HCPV-220H

Ref1. Detailed specifications for the applicable sensor specifications, see the back of the '10. sensor's specifications'.

Caution1. Please make the operating machine(load) be driven with using the power relay or magnet outside surely because its output specification of inside relay is less than 250VAC 2A

5 Program setting method (FOX-1SH(R))

User setting humidity changing



Humi./ Temp. display mode change

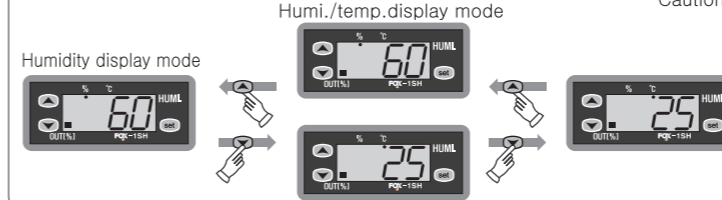

Caution 1 : FOX-1SH(R) is a humidity controller, but the temperature is displayed as an additional function. Please note that the temperature is displayed and not controlled.

Program Settings

Current status display

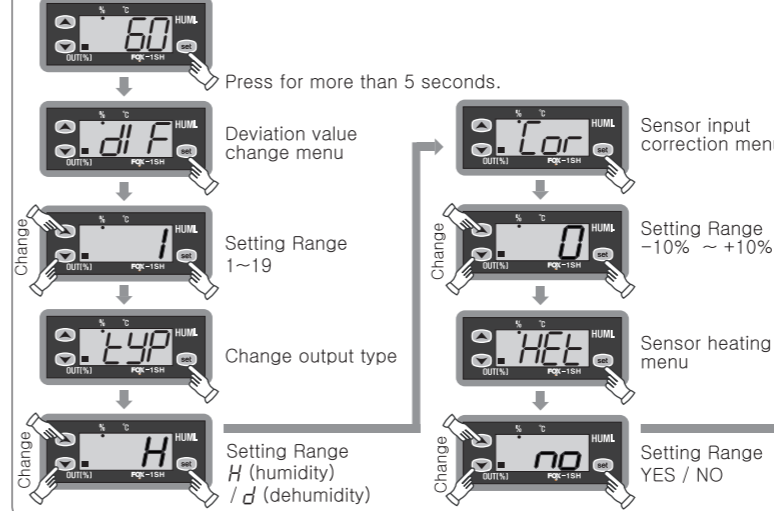

Applicable on a FOX-1SHR only

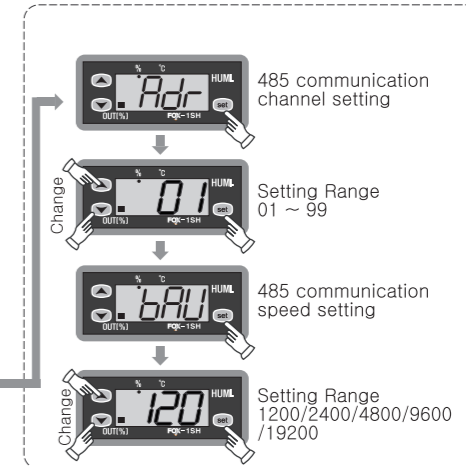

- ※ Press the Set Key continuously for 5 seconds under the current humidity & temperature indicating condition to change to Program Setting Mode.
- ※ All the programs are to be either completed or automatically returned to current humidity with O-K letter after 60 seconds by continuously pressing the Set Key for 3 seconds after completion of setting procedure.

6 Program setting method (FOX-1H)

User setting humidity changing



Program setting

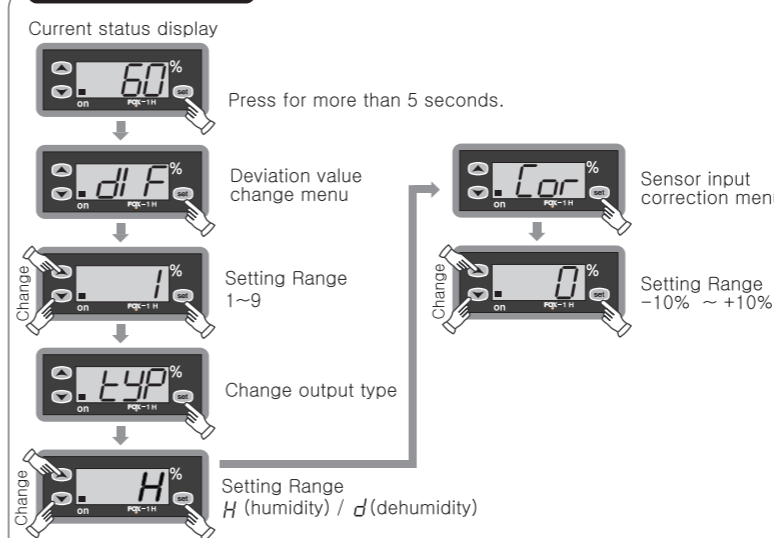

- ※ Press the Set Key continuously for 5 seconds under the current temperature/humidity indicating condition to change to Program Setting Mode.
- ※ All the programs are to be either completed or automatically returned to current humidity with O-K letter after 60 seconds by continuously pressing the Set Key for 3 seconds after completion of setting procedure.

7 Detailed explanation

1 *dIF* Deviation settings FOX-1H FOX-1SH FOX-1SHR

Frequent ON and OFF will shorten the lifespan of the relay or the output contact or cause hunting (generation, chattering) by noise from outside.

To prevent the occurrence, the function protects the contact light of the equipment by setting an interval between ON and OFF in ON/OFF control.

2 *LTP* Output type settings FOX-1H FOX-1SH FOX-1SHR

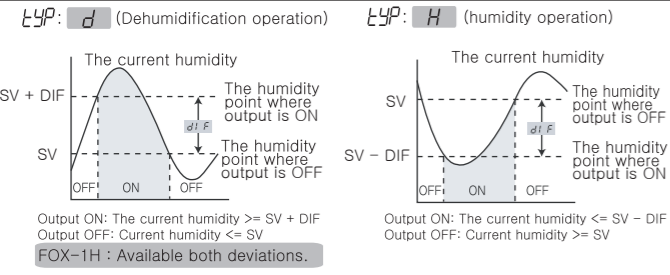

3 *Cor* The current humidity calibration FOX-1H FOX-1SH FOX-1SHR

The function calibrates the current humidity to be consistent with the actual humidity if the humidity shown in the display window and the actual humidity are different despite the product has no problem.
E.g.) Actual Humidity: 55% Rh, Current Humidity: Suppose the Cor value is set -2 when 57% Rh, the current humidity will be displayed at 55% Rh.

Caution 1. The performance of the actual humidity is verified. Please use calibrated equipment for calculation.
Calibration based on humidity calculated with incorrect equipment may cause product malfunction.

4 *HEE* Humidity sensor heating function FOX-1SH FOX-1SHR

Dew forms around the sensor devices if humidity is extremely high; hence, the function generates heat inside the sensor to prevent dew formation if the current humidity is 95% or more.

YES The heating function operates automatically in 95% or more humidity and the function is disabled when humidity level is below 95%.

NO The automatic heating function is not used.

Caution 1. It must be set up "NO" because the heating function can not be used for more than 95%RH.

Caution 2. The present temperature's display can be increased a little while operating of the humidity sensor's heating function.

5 *Adr* RS485 address setting FOX-1SHR

The product FOX-1SHR supports RS485 communications. This function is to set the communication address for mutual recognition with the master device.

6 *bAU* RS485 speed setting FOX-1SHR

This function is to match the communication speed to exchange an accurate data with the master device when using RS 485 communication.

8 Size & dimension

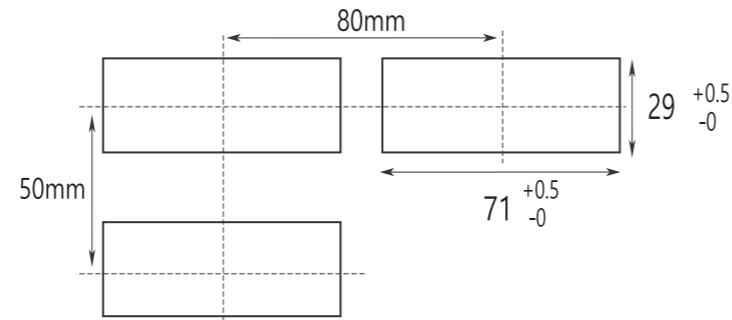
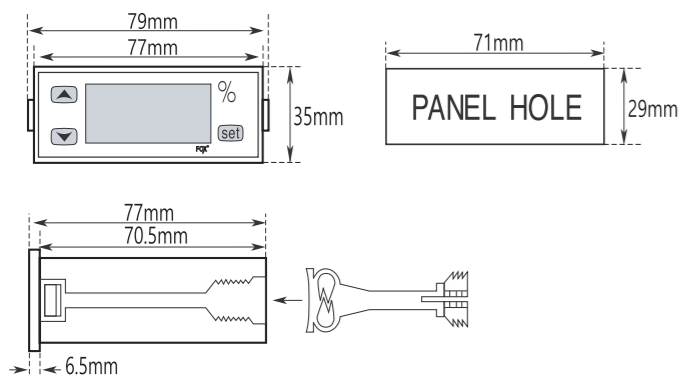

9 Setting range and default set

Model	Function	Range	Default set
FOX-1SH	<i>dIF</i>	1~9, 1SHR(1~19)	1
	<i>LTP</i>	H / d	H (humidification)
FOX-1SHR	<i>Cor</i>	-10 ~ +10	0
	<i>HEE</i>	YES / no	no
FOX-1SHR	<i>Adr</i>	01~99	01
	<i>bAU</i>	120 : 1200BPS	960(9600BPS)
		240 : 2400BPS	
		480 : 4800BPS	
960 : 9600BPS			
1920 : 1920BPS			

10 Application sensor specification

<DS-SH series> FOX-1SH FOX-1SHR

Model : DS-SH[A][H]

A(Humidity Accuracy) **H**(Housing Type)

- 0 : ±4.5% - 04 : Stainless Body Length 40mm(Max. ambient temp.80°C)

- 1 : ±3.0% - 12 : Stainless Body Length 120mm(Max. ambient temp.80°C)

- 5 : ±2.0% - 220 : Plastic Case

Caution1. When using a communication shield wire, the distance sensor installation is within 20m.
Caution2. In addition to using the shield, when using a wire, the distance sensor installation is within 3m.
Caution3. Installation direction refers to the shown below.

DS-SH□12 (surrounding Temp. : ~ 80°C)

DS-SH□04 (surrounding Temp. : ~ 80°C)

DS-SH□220 (surrounding Temp. : ~ 65°C)

< HCPV-220H > FOX-1H

(surrounding Temp. : ~ 65°C)

11 Communication interface (FOX - 1SHR)

specification	in conformity EIA RS485
The method of communication	two wire half-duplex operation
synchronous system	asynchronous system
communication distance	within 1.2Km
communication speed	1200/2400/4800/9600/19200Bps
StartBit	fixed 1bit
StopBit	fixed 1bit
ParityBit	none
DataBit	fixed 8bit
Protocol	BCC

1 System

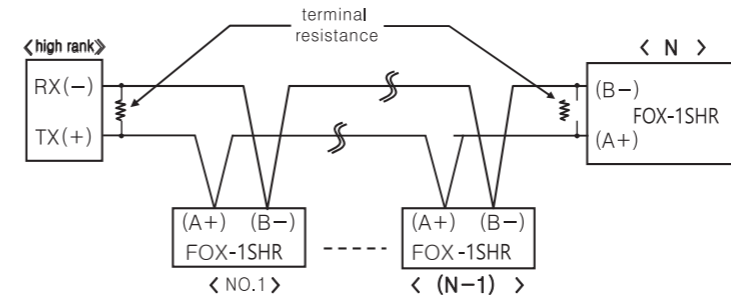

2 Definition between communication command and block

<Host Query format>

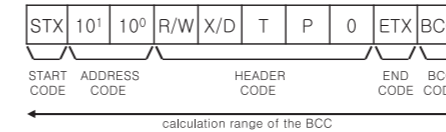

<FOX-1SHR Response format >

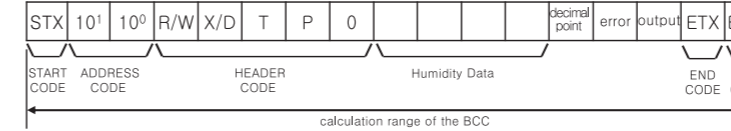

① START CODE

Show the lead(head) of the BLOCK
STX → [02H]

② ADDRESS CODE

A high rank system can discriminate the channel code number among FOX-1SHR. It is available to set between 01 and 99(BCD ASCII)

③ HEADER CODE : Show the command name as an alphabetic letter

RX (reading demand) → R[52H], X[58H]
RD (reading response) → R[52H], D[44H]
WX (writing demand) → W[57H], X[58H]
WD (writing response) → W[57H], D[44H]
TPO (temperature measuring value) → T[54H] P[50H] 0[30H]

④ DATA Composition : Data is displayed as "Hexa decimal" (Negative number: complement of 2)

⑤ Decimal point - 0[30H] there is no decimal point
1[31H] there is a "decimal point"

⑥ Error - 0[30H]: there is no "error" // 1[31H]: the sensor's open error
2[32H]: low error // 3[33H]: high error

⑦ Output - 0[30H] : output OFF // 1[31H] : output ON

⑧ END CODE : show the end(close) of the block. ETX → [03H]

⑨ BCC : (BLOCK Check Character)

Show the XOR arithmetic and logic values from the start(STX) to the ETX.

※Others : As of no response of the ACK

- ① in case of not equivalent to the channel after receiving STX
- ② in case of generating the receive buffer overflow
- ③ in case of not equivalent to the communication's set values or baud rate

▪ treatment : in case of no response of the ACK

- ① check the cable
- ② check the communication's condition(set values)
- ③ if the main cause of the status is the noise, try to do communication practicing 3 times until recovering normally.
- ④ change the communication speed in case of bring about the communication's error frequently.

12 Application for humidity controller

1 What are the setting humidity and the program value to turn off the dehumidifier at 43% Rh and operate at 47% Rh?

User set humidity change : 43%Rh Program Settings *LTP: d* *dIF: 4%Rh*

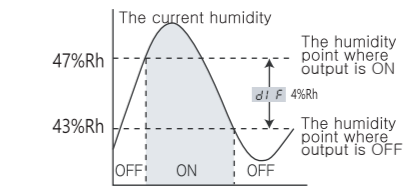

2 What are the setting humidity and the program value to turn off the humidifier at 43% Rh and operate at 40% Rh?

User set humidity change : 43%Rh Program Settings *LTP: H* *dIF: 3%Rh*

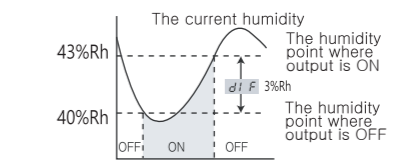

13 A simple troubleshooting technique

■ If error message is displayed while using the product:

▪ *Er1* means damage to the data memory element due to powerful noise impact from outside while using the product. In such a case, contact our company for customer service.

■ While the controller is equipped with supplementary measures for outside noise, the product inside may be damaged if noise in 2KV level is applied to the product.

▪ *o-E* display means communication defect with the sensor. Please check connection, wire short, and connection order to the sensor. If the problem persists, please contact our customer service department.

▪ *L-E* or *H-E* is shown when humidity display has exceeded the range. If the error is displayed despite maintaining normal surrounding humidity, please contact our customer service department.

■ Warranty Period: One year from the date of purchase.

The specifications of the above product are subject to change without a prior notice to improve performance of the product. Please comprehend the contents specified in the above precautions, and observe them without fail.

■ Regarding the manual in English please download it at our website.

H.office : CONOTEC B/D 2nd fl. 26, Yunsan-ro, Geumjeong-gu, Busan, 46269 Rep.of KOREA

A/S TEL : 051 - 819 - 0425 ~ 7
e-mail : conotec@conotec.co.kr
URL : www.conotec.co.kr

■ Installation Precautions
WARNING: TO REDUCE THE RISK OF ELECTRICAL SHOCK, DO NOT REMOVE CONNECT to the protective earth ground and the mains supply. Do not block the vents.

Handling Precautions
■ This Product is suitable in the following environment:
Ambient temperature: 0 C~ 60 C Ambient humidity: 80%Rh max.
Using for indoor only Pollution Degree 2
Altitude 2000 or less Installation Category II
■ Avoid equipment placement that is difficult to operate power cord.
If using the equipment in a manner not specified by the equipment manufacturer may impair the protection provided by the equipment.
■ Rated power: AC 100~240VAC 50/60Hz 3VA

- Main products & Development
- Digital temperature/humidity controller
- Digital timer, Current/voltage meter
- The other development products